

Your Feeding Plan

Type of Feeding Tube: _____ Formula _____

Rinse with _____ ml water every ____ hours, before and after medications placed in feeding tube, before feedings are started and after stopped.

Feeding regimen: _____

****PLACE ICE PACK TO OUTSIDE OF SET IF > 6 HOURS OF FORMULA****

I. Set up of Formula

1. Wash hands. Prepare work area.
2. Open and remove tubing from package.
3. Close the roller clamp on the tubing of the feeding bag.
4. Shake can of formula well then pour amount specified by your doctor, into bag.
5. **Hang bag up**, open roller clamp until formula comes through tubing and let a few drops of formula drip out of end of tubing. Do not over-fill the drip chamber.
6. Close the roller clamp.

II. Load tubing into pump

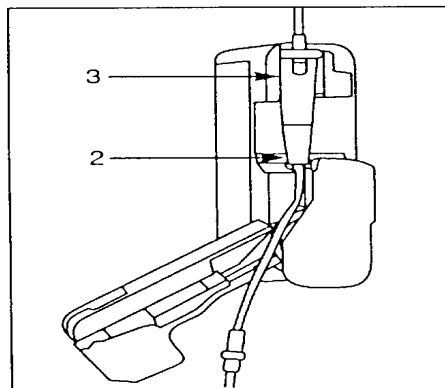
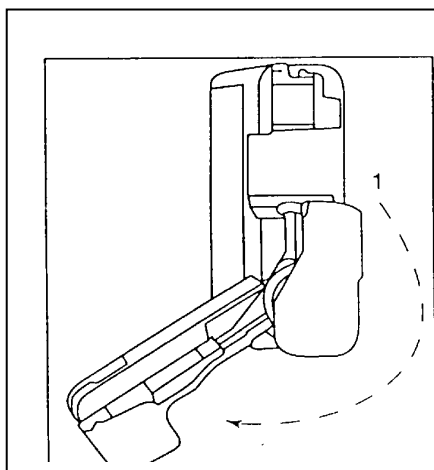

1. Open loading arm by pressing on the black button to unlatch it and rotating the arm clockwise into the fully open position. 2. Insert bottom of drip chamber into lower drip chamber guide. 3. Insert top of drip chamber into upper drip chamber guide.

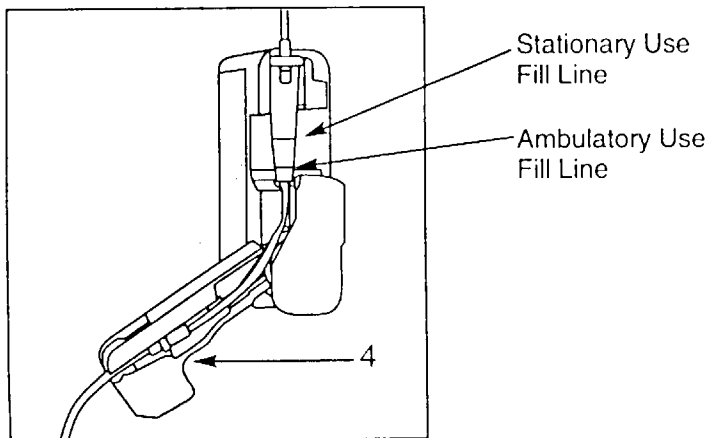

Insert tubing into loading arm.

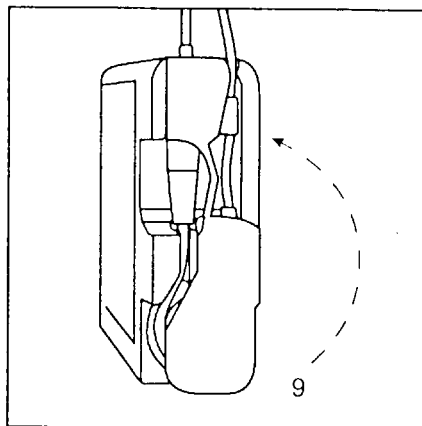

Close loading arm by rotating counterclockwise until it latches shut.

III. Flush feeding tube before hooking up to bag/tubing.

1. Draw up 60 cc water into syringe, connect to feeding tube and slowly flush.
2. Connect end of tubing to feeding tube.
3. **Open the roller clamp.**

IV. Starting pump

1. Press ON
2. Wait while pump performs system check.

3. Rate is displayed in flashing numbers. Change rate by arrows .
(Display may show VOL first, this is total amount given last feeding)
To clear volume push VOL then CLR. Flashing rate will then be displayed.
4. Press START/HOLD. Dots will flash across the top of display across the top, and rotary wheel will turn intermittently.

V. Ending feeding.

1. When feeding is complete, turn pump off.
2. Flush feeding tube with 60cc water and close end of feeding tube.
3. If you meet resistance when flushing, use the clog zapper provided for you with your supplies.

VI . Bag Cleaning.

1. Wash bag after every feeding or every 24 hours with hot, soapy water, drain, rinse with hot water until runs clear.
2. Discard bag after 48 hours of use.

VII. Syringe Change.

60cc syringe used for flushes are to be used for one week, then discarded.

VIII. Pump Battery.

Fully charged battery will operate approximately 14 hours at 125cc/hr.
Occasionally allow the pump to run until LOW BATT alarm occurs and then recharge. A fully discharged battery takes approx. 6 hours to recharge.

PUMP ALARMS

No SEt Check to make sure tubing is placed in pump correctly

FLO Err Refill feeding container. Locate source of occlusion and fix,
(roller clamp closed, drip chamber overfilled, feeding tube clogged)

LO bAt Plug pump into charge base and plug into wall outlet.

Hld Err Pump on hold more than 2.5 min. Press START/HOLD to silence, then press again to restore flashing rate, & then press one more time to restart.

SYS Err or 8888 Turn pump off for a few minutes then turn back on. If persists call nurse for a new pump.

Trouble Shooting

HAVE PUMP ON HOLD OR OFF WHEN TRANSFERRING TO AMBULATORY BAG. SEE AMBULATORY LOADING INSTRUCTIONS.

DRIP CHAMBER MUST REMAIN UPRIGHT AT ALL TIMES OR IT WILL ALARM FLOW ERROR.

Overfilled drip chamber: Disconnect drip chamber & tubing, squeeze extra formula out, reconnect tubing. OR. Empty formula out of bag, & tubing. Start refill process.

Clogged Feeding tube: Instill Clog Zapper as per instructions. If this doesn't resolve clog, call your home care nurse for further instructions.

Dislodged Feeding tube: Turn off feeding and contact your doctor for instructions.

Diarrhea and/or Cramps : Call nurse if five or more liquid stools in one day. Nurse will review with MD to see if administration rate needs to be changed. Prevent bacterial contamination which could cause diarrhea: do not let formula sit out at room temp >6 hours, discard refrigerated formula after 24 hours, wash hands before touching feeding bag tubing or formula, clean and change tubing as instructed.

Nausea, Vomiting or Reflux: When removing formula from refrigerator, allow to come to room temp before using. Elevate shoulders and head 30 to 40 degrees or sit in recliner type chair during feeds.

Thirst / Dry mouth: Keep mouth clean with gentle brushing. Moisten lips with petroleum jelly or other lubricant. Rinse mouth with warm water or mouthwash at intervals during the day.